

1 STORAGE AND PRESERVATION

When despatched, all valves are in the open position, and it is recommended that they be left in this position during storage. All protective packaging, end port plugs/caps, flange covers etc. should remain in position until the valve is due to be installed. Valves should be stored in a clean, dry environment.

Carbon steel valves are coated in a de-watering oil. This coating is non-toxic and is quite safe on edible or potable products.

2 VALVE MARKINGS

Each valve has the following identification information plate attached to the underside of the body:

3-Piece Valves 32mm (1 1/4") and larger:

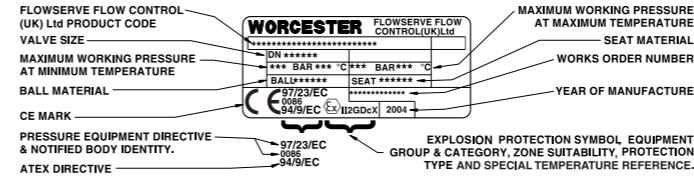

3-Piece Valves 25mm (1") and smaller:

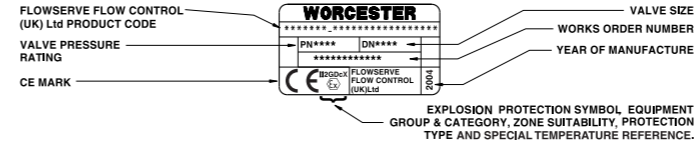

- 2.1 Pressure Equipment Directive: The product will be deemed to be in compliance with the Pressure Equipment Directive 97/23/EC and the Pressure Equipment Regulations 1999 SI 1999/2001 **only** if the 'CE' mark and the Notified Body identity number '0086' appears on the label. Otherwise the product is classified as 'SEP' (Sound Engineering Practice) and may only be used within the limitations defined in tables 6, 7, 8 & 9 of Schedule 3 of the Pressure Equipment Regulations.
- 2.2 ATEX Directive: The product will be deemed to be in compliance with the ATEX Directive 94/9/EC and The Equipment and Protective Systems for Use in Potentially Explosive Atmospheres Regulations 1996 **only** when the 'CE' mark and the Explosion Protection Symbol and codes identifying the equipment group and category, the zone suitability, protection type and the temperature class appears on the label.
 Definition of identity plate marking above:
 'I' = Equipment Group; '2' = Equipment Category; 'G' = Gas Zone suitability (Zones 1 & 2);
 'D' = Dust Zone suitability (Zones 21 & 22); 'c' = type of protection i.e. constructional safety (prEN 13463-5).
 'X' = Special temperature reference (Surface Temperature: As per EN 13463-1:2001(E) para graph 14.2.g, the temperature class or maximum surface temperature cannot be marked on the product, as it is dependent on the operating conditions. However, for valve sizes DN32-DN50, the maximum/minimum allowable operating temperatures for the product is marked on the identification plate. Refer to the product brochure and/or Flowserve Flow Control (UK) Ltd. Technical Sales for allowable temperature limits for all other sizes).
- 2.3 Should the valve soft trim materials be changed during the course of its operational life it is necessary for this change to be reflected on the identification plate i.e. material change may impact pressure and temperature limitations. Refer to Flowserve Flow Control (UK) Ltd. Technical Sales for details.
- 2.4 Material traceability markings are hard marked on the valve body and connector.

5 INSTALLATION INSTRUCTIONS

5.1 GENERAL

Valves fitted with a flow arrow are uni-directional and must be installed with the arrow pointing down stream. Valves without flow arrows are bi-directional and may be installed in either direction.

5.2 SCREWED END VALVES:

Do not dismantle these valves to install. Ensure that the pipeline and valve end threads are clean. Apply a suitable thread sealant to the pipe threads and screw into the valve being careful not to over tighten tapered threads. Do not use the valve stem as a lever to tighten the valve onto the pipe thread.

5.3 WELD END VALVES:

- a) Remove the actuator by removing the mounting screws. Ensure that the coupling set screws are also loosened. Do not remove the coupling from the actuator. Store in a safe, clean area. With the valve in the OPEN position, remove the body bolts.
- b) Turn the ball to the closed position and push out the ball and one seat, retaining as much grease as possible between the ball and seat. Remove the second seat (retaining the grease). Store in a clean area.
- c) Re-assemble the valve end connectors to the body in the correct alignment using two diagonally opposing body bolts.
- d) Align the assembly in the pipeline and tack weld only into position.
- e) Remove the valve body from the pipeline (to prevent damage to the stem assembly seals) and complete the welds ensuring that the body connector sealing faces are protected from weld spatter.
- f) When cool, clean the body connector sealing faces, fit the ball, seat rings and new body seals supplied back into the body and turn the ball to the open position. Ease the valve body between the end connectors being careful not to damage the sealing faces, seats and seals. Replace the body bolts and tighten to the recommended torque. See also Sections 9 & 10 for detailed instructions. If the valve is fitted with a flow arrow, ensure that it is pointing downstream.

3 HEALTH AND SAFETY

When installing or maintaining valves:

- a) Conduct a risk assessment and eliminate or reduce hazards to an acceptable level.
- b) Work in accordance with Safe Systems of Work.
- c) Observe all site Health and Safety Rules in particular Permit to Work and Hot Work procedures.
- d) Wear all necessary Personal Protective Equipment.
- e) Never remove or maintain a valve or joint unless the line has been fully de-pressurised, drained and where necessary, purged of toxic / explosive / flammable media. Always operate the valve to the open position to ensure that no trapped pressure exists within the cavity.
- f) Never handle valves that have been used on harmful substances unless they have been completely decontaminated and certified safe to handle.
- g) Never use a valve on a duty, which exceeds its prescribed operating parameters. Refer to Flowserve Flow Control (UK) Ltd. Technical Sales for performance curves or further information.
- h) Never modify or alter valves unless the manufacturer has been consulted and/or recommends such changes.
- i) Due to the large physical size and weight of some sizes of this product, always use correct lifting methods and equipment when installing, removing and maintaining the product, and that it is correctly supported in its final operating location.
- j) Due to the variety of duties on which this product can be employed, it is the end users responsibility to ensure the compatibility of the media with the materials of construction of the product for each specific application (i.e. corrosion and erosion which may affect the integrity of the pressure-containing envelope).
- k) Before equipment is installed in areas which may be subject to seismic activity or extreme climatic conditions consult Flowserve Flow Control (UK) Ltd. Technical Sales.
- l) Lethal Service. In accordance with the design verification code (2001 (2003 addenda) ASME Boiler and Pressure Vessel Code Section VIII Division 1) a casting quality factor of 1.0 is allowable for all products. Those intended for 'lethal service' must have had non-destructive examination carried out in accordance with Appendix 7 of the code. Refer to Flowserve Flow Control (UK) Ltd Technical Sales.
- m) If the processes or environments that the products are used in are likely to cause temperatures (high or low) that may cause injury to personnel if touched, then adequate insulation/protection must be fitted.
- n) If the equipment is to be used on unstable gas duty, ensure that the operational parameters as indicated on the product identification plate, or in the product brochure, or as advised by Flowserve Flow Control (UK) Ltd. Technical Sales cannot be exceeded.
- o) This equipment should be protected by other devices to prevent over-pressurisation. (i.e. caused by external fire etc).
- p) This equipment must be installed in a system that is designed to prevent excessive forces acting on the flanges, connections, etc.

6 OPERATION

6.1 USE

Worcester control valves fitted with a resilient seat downstream provide bubble tight shut off when used in accordance with Worcester's published pressure / temperature charts. Valves fitted with a metal seat downstream provide shut off to FCI 70-2-1998 Class VI.

Any media, which may solidify, crystallise or polymerise, should not be allowed to stand in the ball cavity, as this is detrimental to valve performance and life.

6.2 MANUAL OPERATION:

Worcester control valves are designed to be automated with either electric or pneumatic actuators. Flowserve Flow Control (UK) Ltd. can supply these to cover a wide range of operating torque requirements.

Operation of these will be in accordance with the Installation, Operation & Maintenance Instructions for the relevant actuator.

7 MAINTENANCE

7.1 GENERAL

With self-wipe ball / seats and patented pressure equalising slots (resilient seat only), Worcester valves have long, trouble free lives and maintenance is seldom needed. The following checks will help extend life further and reduce plant problems:

Routine checks / maintenance:

- Every 25000 cycles or 3 months: Check for any signs of leakage (see 7.2, 7.3 & 7.4 below) and that all fasteners (including the gland nut) and joints are tightened to their correct torque value (see Section 10 of this I.O.M.).
- Infrequent operation: The valve should not be left standing without operation for more than 1 month. After this period the valve should be operated through three full cycles.

7.2 IN-LINE LEAKAGE

Check that the valve is fully closed. If it is, then any leakage will be due to damage to the body, connector, ball or seat sealing surfaces and it will be necessary to repair it (refer to Section 9 and 10). **Note:** Metal seats fitted downstream provide shut off to FCI 70-2-1998 Class VI.

7.3 STEM LEAKAGE

Remove the actuator (as detailed in the relevant actuator I.O.M.), followed by the gland nut locking clip and retighten the gland nut to the recommended torque.

If leakage still persists then it will be necessary to dismantle the valve to establish the cause and/or to replace the stem thrust seal and gland packing/s (refer to Sections 9 and 10).

7.4 BODY / CONNECTOR JOINT LEAKAGE

Check the tightness of the body bolting and tighten to the recommended torque values if necessary. If leakage still occurs it will be necessary to remove the valve from line to replace the body seal and to establish whether the seal faces of the body and connector have been damaged. (See section 9 & 10).

9.2 REBUILDING

- Before rebuilding, ensure the repair kit and/or components used are suitable for the valve requirement. When rebuilding, cleanliness is essential for long valve life.
- Fit a new stem thrust seal on to the stem shoulder and insert this into the body stem bore from inside the body cavity.
- Temporarily fit two metal glands, and one pair of disc springs (with their outer edges touching) followed by the gland nut. Tighten the gland nut until the disc springs are flat. Operate several times to bed in the thrust seal.
- Remove the gland nut, disc springs and temporary glands.
- Coat the graphite gland packing with Bentone Grease No.1 and fit into the body recess, followed by the gland packing protector (tan in colour), metal gland and new disc springs.
- Fit the gland nut, and using a wrench (or other means) to prevent the stem from turning, tighten it down to compress the disc springs. Operate the stem several times, then tighten the gland nut to the torque specified in Section 10.
- The locking clip must be fitted correctly: either across the corners or the flats of the gland nut. The gland nut can be tightened to the next position to correctly locate the clip (see below).

NOTE: Over tightening will only reduce the life of the stem assembly.



- Fit the graphite or PTFE seal into the recess in the back face of the metal seat. Apply Bentone Grease No.1 to both sides of the seat and the exposed back face of the seal. Fit the metal seat into the valve body. If the seat is characterised (i.e. 30°V), ensure that the slot in the outside diameter locates onto the orientation pin in the body.
 - Apply Dow Corning DC200 to the metal seated side of the ball only and assemble into the valve body.
- Fit the original or a spare metal seat ring complete with compressed graphite seal (pre-compression aid) in the other end. Replace the valve between the end connectors or using spare end connectors, and with the ball in the open position, fully tighten the body connector bolts to the torque specified in section 10.
- Remove the body connector bolts and the valve centre section. Remove the spare seat ring.
- Fit the new 'Fluorofill' seat ring and the new body seals ready for final assembly.
- The body connectors must have their faces cleaned before refitting of the valve can proceed. As with removal, the body connectors must be sprung apart slightly to get the body assembly into position and avoid damaging the seats, seals and sealing faces.
- Centralise the body, replace the body connector bolts and tighten diagonally and evenly to the torque specified in Section 10.
- If practical, check for leak tightness and operating torque.

8 REPAIR KITS

Repair kits are available for all Worcester control valves. Control valves have special features over standard valves and as such repair kits for standard valves must not be used. Details of their contents can be found on the instruction sheet supplied with the kit.

If other parts are required, it is usually recommended that the complete valve be replaced (although piece parts are available). Parts from different sized/rated valves must not be interchanged.

Only Worcester authorised spare parts should be used. This includes basic components such as fasteners. Flowserve Flow Control (UK) Ltd will accept no responsibility if the valve is altered in any way with out the consent of Flowserve Flow Control (UK) Ltd.

10 VALVE ASSEMBLY TORQUES

10.1 BOLTING TORQUES

It is a requirement of all body bolts to give a metal to metal contact between the body and the inner surface of the body connectors.

Hexagonal Headed Bolts			Socket Head Cap Screws		
Valve Nominal Size		Recommended Torque (Nm)	Valve Nominal Size		Recommended Torque (Nm)
Reduced Bore	Full Bore		Reduced Bore	Full Bore	
15mm (½")	-	11 - 13	15mm (½")	-	24 - 28
20mm (¾")	15mm (½")	13 - 15	20mm (¾")	15mm (½")	25 - 28
25mm (1")	20mm (¾")	24 - 28	25mm (1")	20mm (¾")	27 - 31
32mm (1¼")	25mm (1")	28 - 32	32mm (1¼")	25mm (1")	31 - 35
40mm (1½")	32mm (1¼")	33 - 37	40mm (1½")	32mm (1¼")	35 - 39
50mm (2")	40mm (1½")	38 - 42	50mm (2")	40mm (1½")	49 - 53

10.2 GLAND NUT TORQUES

These are the figures for tightening plain gland nuts, which are used in conjunction with gland nut locking clips. They are not to be used for tightening self locking gland nuts.

Graphite Seals			PTFE Seals		
Valve Nominal Size		Recommended Torque (Nm)	Valve Nominal Size		Recommended Torque (Nm)
Reduced Bore	Full Bore		Reduced Bore	Full Bore	
15mm (½")	-	5 - 7	15mm (½")	-	6 - 9
20mm (¾")	15mm (½")	5 - 7	20mm (¾")	15mm (½")	6 - 9
25mm (1")	20mm (¾")	6 - 10	25mm (1")	20mm (¾")	8 - 12
32mm (1¼")	25mm (1")	6 - 10	32mm (1¼")	25mm (1")	8 - 12
40mm (1½")	32mm (1¼")	8 - 12	40mm (1½")	32mm (1¼")	13 - 18
50mm (2")	40mm (1½")	8 - 12	50mm (2")	40mm (1½")	13 - 18

10.3 STEM ASSEMBLY TORQUES

The following figures are for your guidance only. The torques quoted are those to operate the stem assembly before the ball and seats are fitted.

Valve Nominal Size		Recommended Torque (Nm)
Reduced Bore	Full Bore	
15mm (½")	-	3 - 5
20mm (¾")	15mm (½")	3 - 5
25mm (1")	20mm (¾")	4 - 6
32mm (1¼")	25mm (1")	4 - 6
40mm (1½")	32mm (1¼")	6 - 8
50mm (2")	40mm (1½")	6 - 8

9 REFURBISHMENT INSTRUCTIONS

GENERAL: Prior to commencing any work on the valve or removing it from line, refer to the 'Health & Safety' Instructions.

NEVER remove or maintain a valve or joint unless the line has been fully de-pressurised, drained and where necessary, purged of toxic / explosive / flammable media.

Ball and stem: 15mm to 50mm control valves are fitted with matched ball and stem to reduce backlash (hysteresis). If either the ball or stem needs replacing, then both items must be replaced with another matched pair.

When despatched, V-Flow control valves contain special lubricants which aids the bedding in of the valve and ensures smooth modulating operation. This will ensure long life on control valves with metal seats

V-Flow characterised seats i.e. 30°V, 60°V, etc, must be properly orientated for proper function:

A location pin is provided in the body, and a groove in the seat, to ensure proper alignment is accomplished.

All of the following rebuilding instructions refer to valves with metal seats fitted in one end. If the valve is fitted with resilient seats (i.e. 'Fluorofill') in both ends or metal seats in both ends, then the procedure for pre-compression of seat seals in NOT required and should be ignored.

9.1 DISMANTLING

a) There are two methods of removing a valve from the pipeline. In both cases:

- The valve must be in the open position (with the stem flats in-line with the pipeline) to prevent the ball protruding out of the body and fouling on the body connectors when the body is removed, and,
 - The body connectors must be sprung apart slightly to prevent scoring of the machined faces. For fire-safe valves, and/or valves with characterised metal seats, the connectors must be pulled apart even further to allow clearance for the fire-safe body seal spigot and/or the back face, dished side of the characterised seat.
- b) Method 1: 'Slide-out' method: (see Figure 1). Extract all of the body bolts and slide the body complete from the two body connectors. Care must be taken not to damage the connector sealing faces.

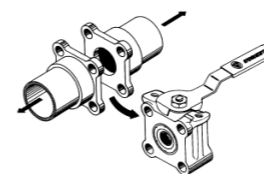

Figure 1: 'Slide-out' method

9.1 DISMANTLING (cont.)

- Method 2: 'Swing-out' method: (see Figure 2). If only partial removal from the pipeline is required (i.e. to change seats, seals or ball only), then extract all of the body bolts bar one, which is only loosened. The body may then be rotated from between the two body connectors using the last remaining bolt as a pivot.

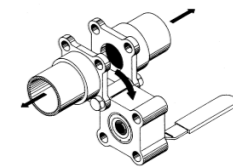
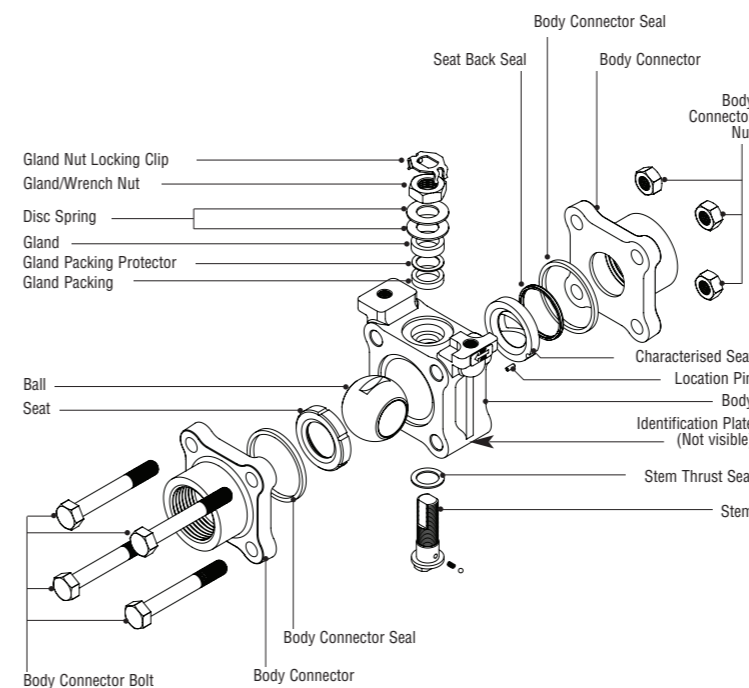

Figure 2: 'Swing-out' method

- Once the body is clear of the connectors, half close the ball, remove and discard the seats. Complete the closing turn and the ball may be removed. This must be done with care, otherwise the ball may mark against the body.
- The body seals can now be removed and discarded. Again care must be taken not to damage the machined faces on which they seal. Note: If the valve is being dismantled to cure through leakage (i.e. to replace ball and seats), and there is no stem leakage, then it is not necessary to go any further with dismantling.
- To dismantle the stem assembly, remove:
 - Gland Nut Locking Clip
 - Gland Nut
 - Disc Springs
 - Gland
- Withdraw the stem from inside the body and remove the stem thrust seal from inside the body recess. **Note:** with 15mm (½") valves, the stem flats must be aligned across the valve to allow with drawal of the stem. The gland packing can now be removed from the body top recess.
- All components not replaced by items in the repair kit should be thoroughly cleaned and stored in a secure area. All sealing surfaces on the body, connectors (including fire-safe spigot), ball and stem should be checked for corrosion, erosion and scratches. If any damage is found, or if there is any doubt over the suitability of the part, then it must be replaced.
- Cleaning of parts may be carried out using a suitable degreasing agent. Hard deposits can be removed using wire wool. Again, care should be taken not to damage any of the sealing surfaces.

THE V44/V59 VALVE



3-PIECE VALVE CHARACTERISED SEAT DETAIL

LOCATION

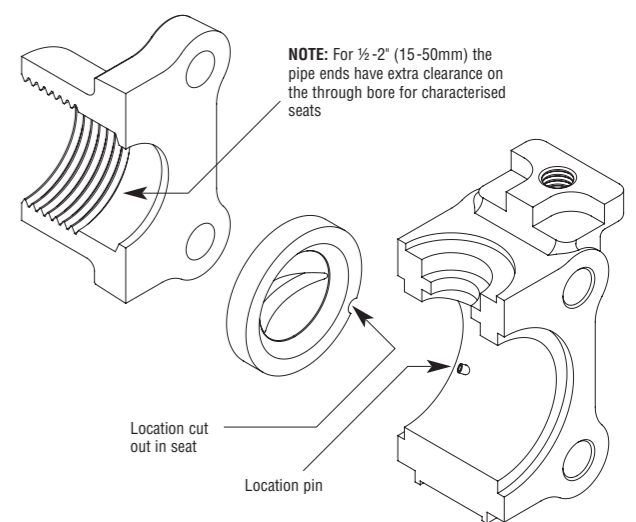

NOTE: For ½-2" (15-50mm) the pipe ends have extra clearance on the through bore for characterised seats