

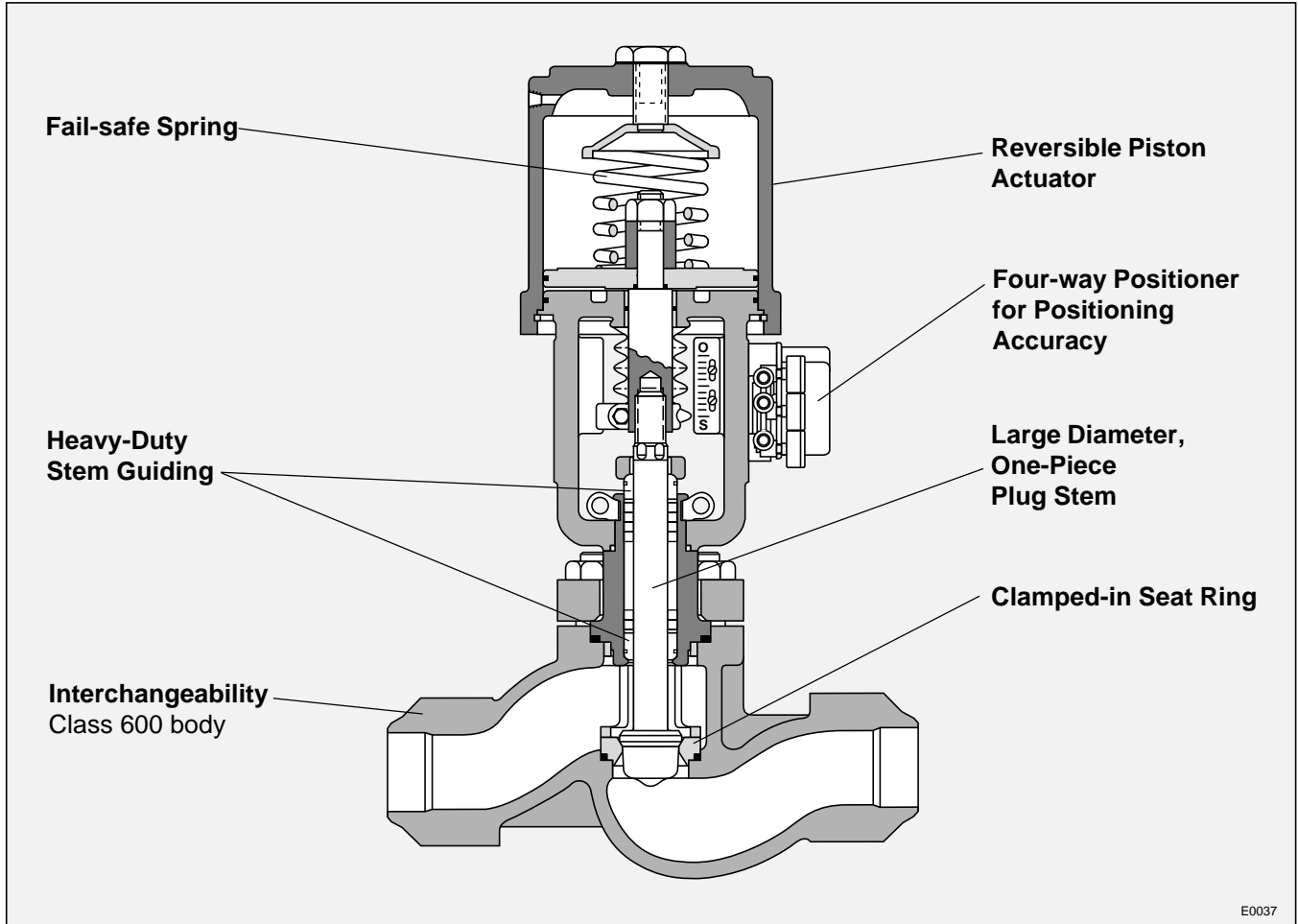

***Valtek Mark One***  
***for Power Services***

# Valtek Mark One-Power

## Introduction



**Figure 1: Valtek Mark One-Power™ Control Valve**

The Valtek® Mark One-Power™ globe control valve offers superior performance in liquid and gaseous services, while permitting easy, fast and inexpensive maintenance in power services.

The Valtek Mark One-P is the ideal choice for high temperature and pressure applications, which demand precise throttling. Factory Mutual approval for use as a fuel service valve and ASME “N” stamp also adds to its versatility in power services.

Unlike diaphragm-operated control valves, the spring cylinder-actuated Valtek Mark One-P provides stiffness and maintains high-positioning accuracy, repeatability, controlled high speed and faithful response. Intense fluid pressures are easily controlled by the compact, yet powerful design. Each actuator is capable of utilizing supply pressures up to 150 psi (10.3 Bar).

Most diaphragm actuators rely entirely on springs to close the valve. The Valtek Mark One-P's spring, supply air pressure and fluid pressure combine to produce exceptionally tight shutoff. A heavy-duty, one-piece plug and self-aligning seat ring further enhance the shutoff capability of the Valtek Mark One-P.

The clamped-in seat, top-entry trim also permit easy, quick maintenance. A high degree of parts interchangeability results in fewer inventory parts. The actuator is lighter, smaller and easier to handle than comparable diaphragm actuators.

The Valtek Mark One-Power control valve is the ideal control valve solution for power services.

## Valtek Mark One-Power

### Valtek Solution

The Valtek Mark One-Power control valve offers solutions to many power services challenges. Five basic configurations (globe, angle, three-way, expanded outlet and Y-body) can be used in various steam, water, fuel and chemical applications. Several anti-cavitation and noise reduction trims, full ASME “N” capability and FM fuel valve approval also expand the service usability of the Valtek Mark One-P.

Common Control Valve Problem	Mark One-Power Solution
Yoke breaks	Ductile iron yokes are highly resistant to breakage
Plug head comes off; stems break	One-piece plug head and stem; stems are heavy-duty – at least two times the diameter of most manufacturers' stems
Valve leaks	Double-acting, high-thrust cylinder actuator allows most applications to avoid pressure-balanced trims and to use the fluid to assist valve closure; self-centering seat assures tight shutoff with no lapping required; Alloy 6 hard facing or 416 stainless steel heat treated trim reduces wire draw and seat surface damage
Actuators destroyed by	Actuators are available with Viton® O-rings for operation to 350° F / 177° C; high temperatures high-temperature positioners are also available
Packing leaks	Heavy-duty, double top stem guiding eliminates lateral stem movement – increasing packing life
Difficult to attach plug and	Threaded actuator stem and one-piece stem clamp makes assembly actuator stem quick and easy
Hard to remove seat or retainer	Clamped-in seat allows for easy removal – no corroded threads to hinder service work
Difficult to remove yoke/	Two stainless steel half-clamps make actuator removal easy – even after bonnet nut years of service
Space constraints in existing	Compact actuator design assures the valve will fit in the existing space piping
Large spare parts stock required	Greater interchangeability such as three standard actuators and a minimum Class 600 body reduces the amount of spare parts required
Severe service applications	The Valtek Mark One-P valve can easily be engineered with severe within the plant service trims: CavControl™, ChannelStream®, MegaStream™ and Tiger-Tooth™; body and trims are available in most materials to meet application requirements
Difficult to service	The Valtek Mark One-P valve has top-entry trim, a clamped-in seat ring, and one-third the parts of other manufacturers' valves; actuator is lightweight and easier to handle than diaphragm actuators.
Unstable flow control	Spring cylinder actuator with 4-way positioner accepts 150 psi / 10.3 Bar air supply ensuring high thrust, low hysteresis and low repeatability

# Valtek Mark One-Power Components

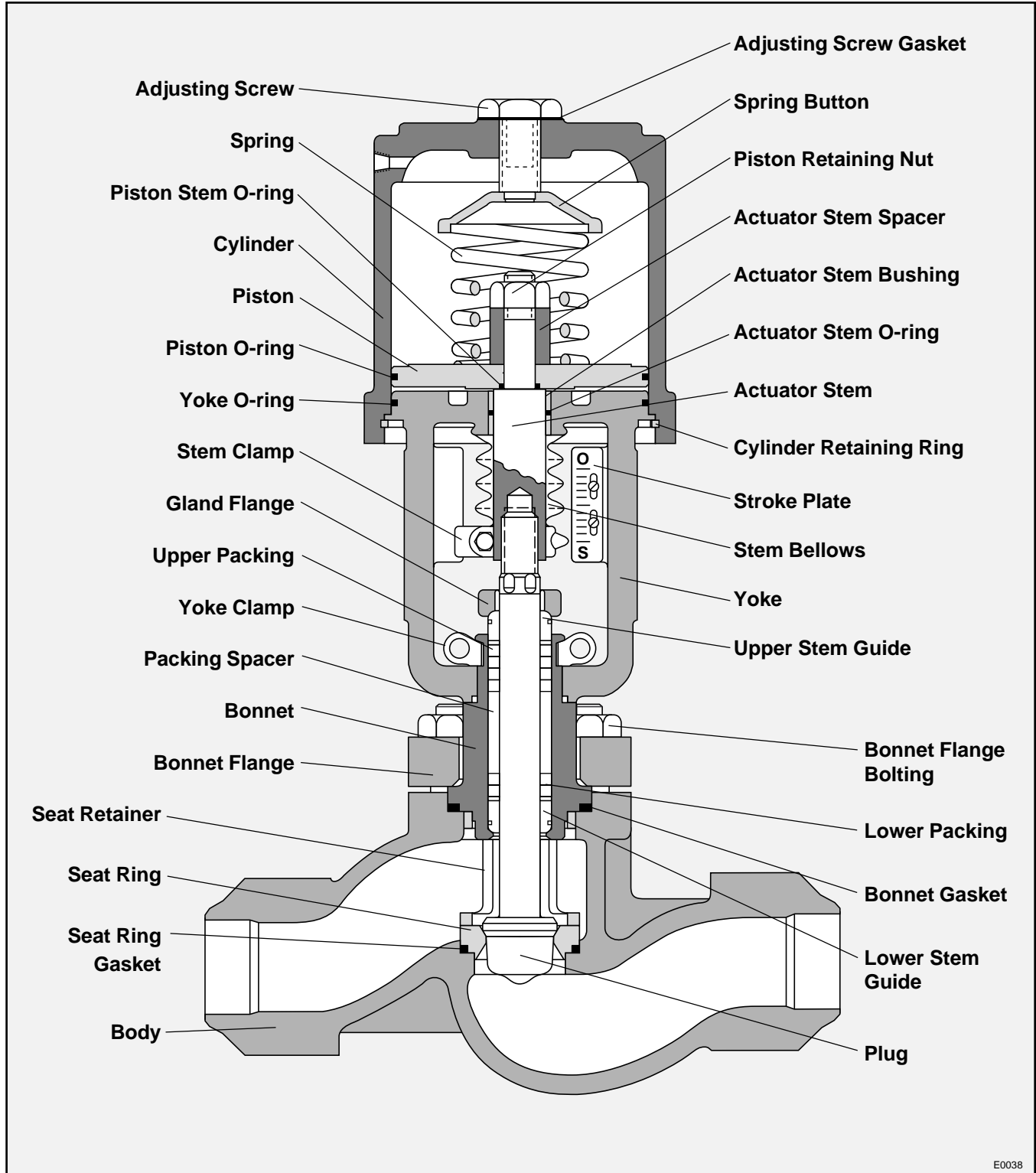

**Figure 2: Valtek Mark One-Power Control Valve**

## Valtek Mark One-Power Body Styles

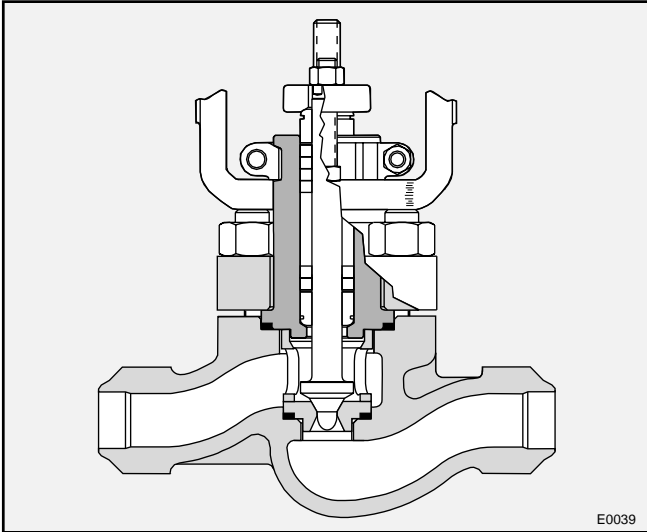

**Figure 3: Globe-style Body**

Globe-style bodies feature smooth, streamlined, constant area internal passages with no pockets, permitting high capacity with minimum turbulence. They are designed with nearly constant wall thickness, providing lower weight and cost when the body is manufactured in expensive stainless or alloy steels.

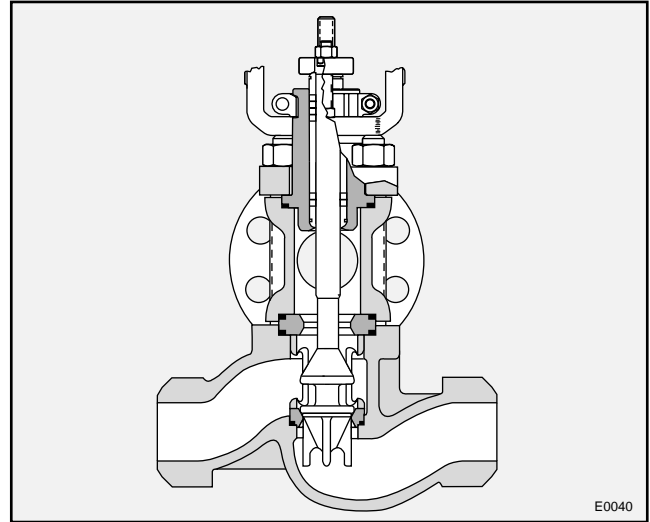

**Figure 4: Three-way Body**

Three-way bodies are used for either combining or diverting services. Due to excellent parts interchangeability, a standard globe valve easily converts to three-way service with the addition of a three-way adaptor, upper seat ring, two gaskets and a three-way plug.

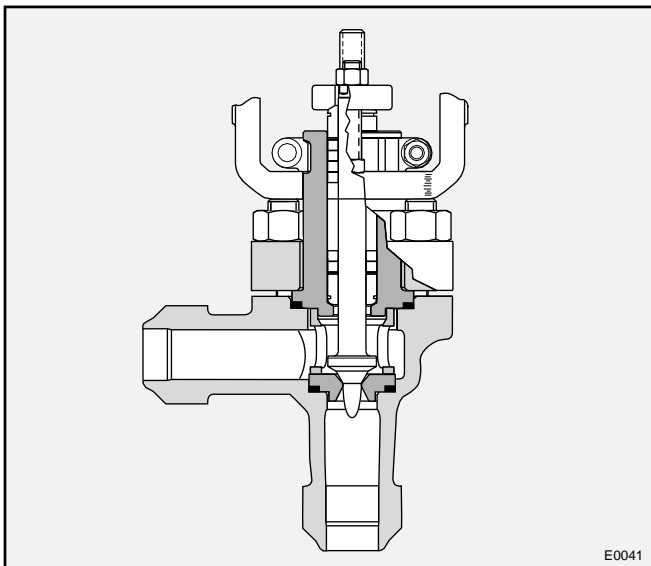

**Figure 5: Angle-style Body**

The Valtek Mark One-Power can be easily adapted to an angle style body – all other valve parts remain the same. For additional protection of the body, a special venturi seat ring, which extends to the outlet flange, is available if required.

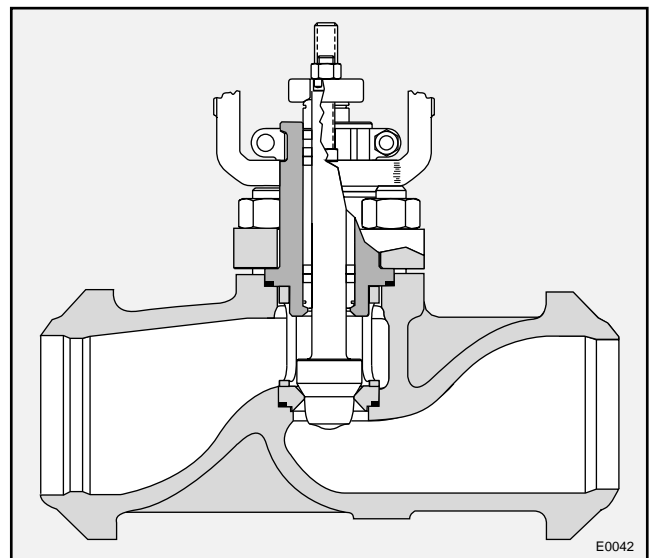

**Figure 6: Expanded Outlet Body**

When a small control valve is needed in a large pipe, the expanded outlet body can be used – all other parts are interchangeable with the globe body. Many power plants use this valve design in heater drain applications.

## Valtek Mark One-Power End Connections

Valtek Mark One-Power end connections are available in five configurations including butt weld, socket weld, threaded, raised face integral and raised face separable. The five end connections make the Valtek Mark

One-P valve applicable to all power industry applications. In addition, Flowserve can custom engineer end connections to meet individual needs.

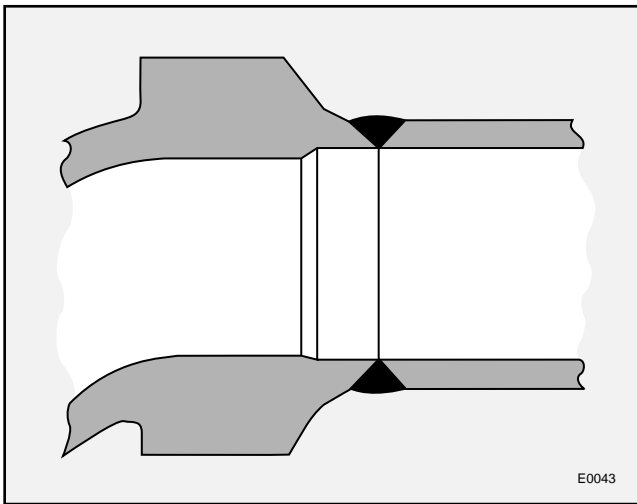

**Figure 7:  
Butt weld End Connection**

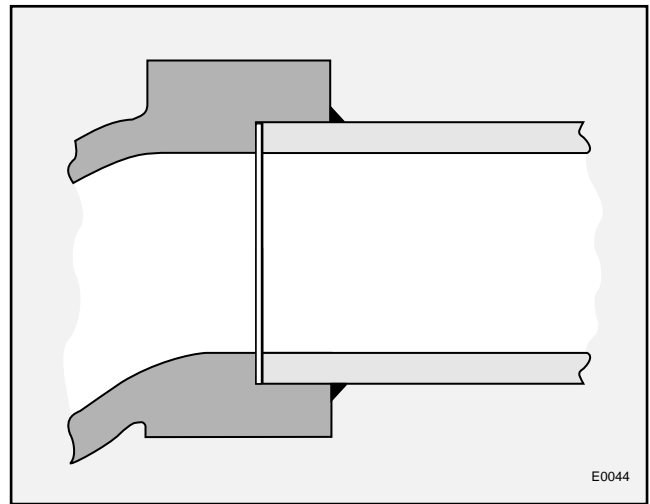

**Figure 8:  
Socket weld End Connection**

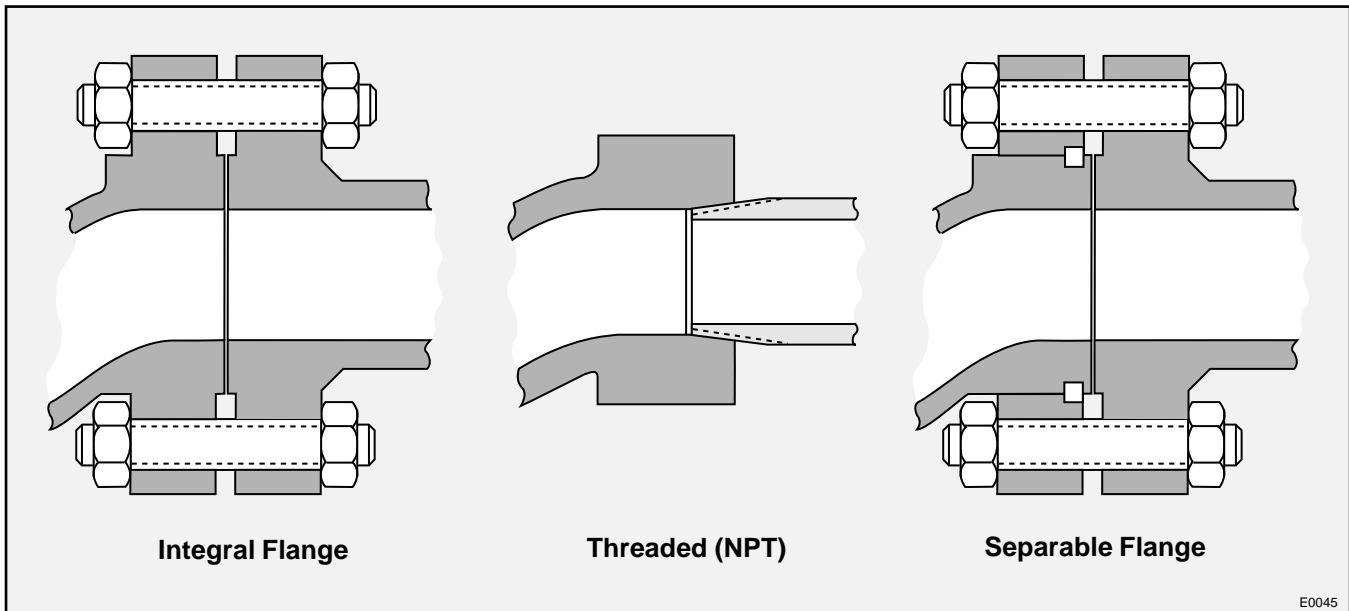

**Figure 9: Additional End Connections**

## Valtek Mark One-Power Gaskets, Yoke Clamps

The Valtek Mark One-P is designed with the bonnet and seat ring gaskets fully retained. The bonnet clamps metal-to-metal in the body creating a primary seal, which is backed up by the gasket. The bonnet gasket compression is determined by the depth of the gasket step on the bonnet, which is machined to provide the necessary gasket compression. Having the bonnet secured metal-to-metal in the body also ensures proper vertical plug alignment in the seat to help maintain tight shutoff.

When the bonnet is fully installed, force is transmitted through the seat retainer to secure the seat ring in position. Compression of spiral-wound gaskets prevents leakage and the self-centering seat ring mates with the plug head, without the need for lapping.

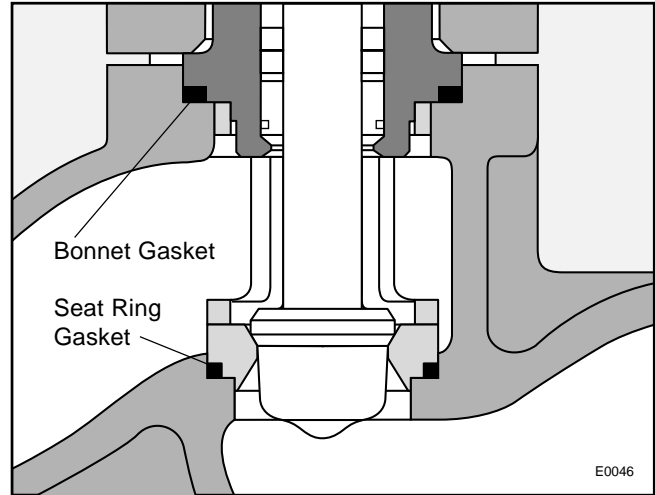

Figure 10: Body Gaskets

Table I: Gasket Specifications

General Temperature Rating	Type	Gasket Material	Maximum Gasket Temp. ° F / ° C	Minimum Gasket Temp. ° F / ° C
Low	Flat	PTFE	350 / 177	-200 / -130
Medium	Spiral Wound	316 S.S. w/ graphite*	750 / 400	-20 / - 30
High**	Spiral Wound	INCONEL® w/ graphite	1000 / 538	-20 / - 30

\* Valtek Mark One-P standard gasket material

\*\* Higher temperatures are available with special gasket designs

### Yoke Clamps

The actuator is commonly attached to the Valtek Mark One-P body assembly with two precision-cast, stainless- steel yoke clamps, although on large valves the actuator is bolted directly to the bonnet. Each clamp has an inclined plane surface which, when bolted together, securely fastens the actuator yoke to the bonnet. Unlike conventional threaded clamps, the Valtek Mark One-Powers' clamp design permits easy removal even under extremely dirty or corrosive conditions.

Associated bolts and locknuts are supplied in plated carbon steel, although stainless steel is also available when required.

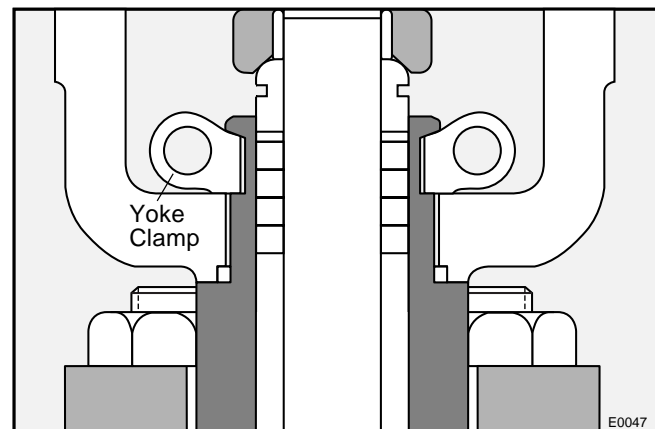
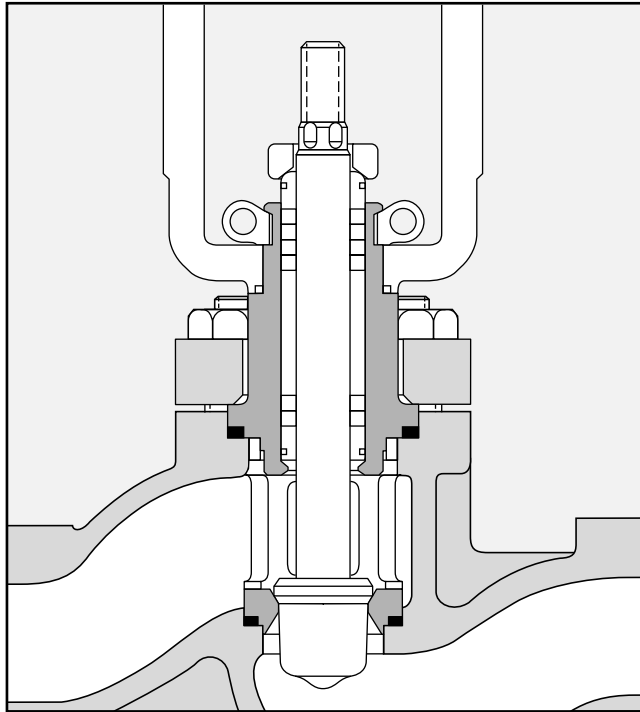
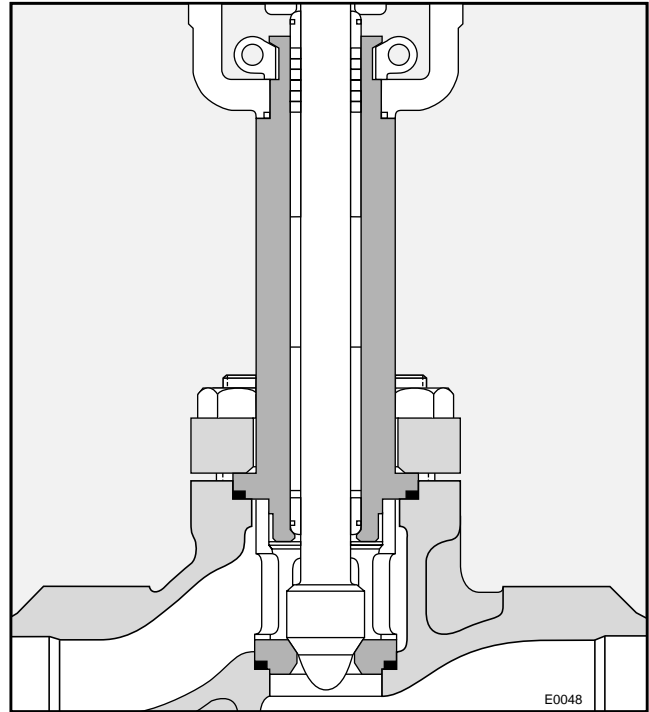

Figure 11: Yoke Clamp

## Valtek Mark One-Power Bonnet Types, Packing Box



Standard Bonnet



Extended Bonnet

Figure 12: Valtek Mark One-P Bonnet Types

### Standard Bonnet

The Standard Valtek Mark One-P bonnet is constructed of the same material as the body and handles temperatures up to 750° F / 400° C in Class 150 – 600 body designs and to 800° F / 427° C in Class 900 – 2500 body designs. (See Table 3 on page 9 for packing limitations.)

### Extended Bonnet

The extended bonnet protects the packing from excessive heat, which may inhibit valve performance. Carbon steel constructions can withstand temperatures up to 800° F / 427° C and 316 stainless steel configurations can withstand temperatures from -150° F to 1500° F / -100° C to 816° C.

### Packing Box

Standard Valtek valve packing boxes are deeper than most conventional types, providing these advantages:

1. The spacing between the wiper set and the main, upper packing set prevents contamination of the upper packing. The upper set is positioned far enough away from the wiper set to avoid contact with any part of the plug stem that has been exposed to the flowing medium. The wiper set is designed to minimize the amount of fluid on the plug stem.
2. Bonnets are designed to permit a wide variety of packing configurations, including a double set of packing, without changing bonnets.
3. Two widely spaced stem guides, when used with Valtek Mark One-Power's large-plug stem diameter, provide exceptional guiding. The upper stem guide also acts as a packing follower; the lower guide is situated close to the plug head for additional guiding support, ensuring accurate alignment of the plug and seat ring.
4. Solid lower guides (bronze or Alloy 6) are used in all high differential-pressure services to ensure rigid guiding and no stem movement. Limiting lateral stem movement (wobble) extends packing life.



## Valtek Mark One-Power Packing and Guiding

**Table II: Packing Temperature Limitations for Standard and Extended Bonnets**

Valve ANSI Rating	Packing Material/Type	Standard Bonnet <sup>(1)</sup>		Extended Bonnet <sup>(1)</sup>	
		° F	° C	° F	° C
150 - 600	Asbestos-free packing AFPI <sup>(5)</sup>	-20 to 750 <sup>(4)</sup>	-30 to 400	-20 to 1200	-30 to 650
	Graphite <sup>(6)</sup>	-20 to 750 <sup>(4)</sup>	-30 to 400	-20 to 1500	-30 to 816
	PTFE	-20 to 450	-30 to 232	-150 <sup>(2)</sup> to 600	-100 to 316
	Braided PTFE <sup>(3)</sup> Glass-filled PTFE	-20 to 500	-30 to 427		
AFPI <sup>(5)</sup> 900 - 2500	Asbestos-free packing	-20 to 800	-30 to 427	-20 to 1200	-30 to 650
	Graphite <sup>(6)</sup>	-20 to 800	-30 to 427	-20 to 1500	-30 to 816
	PTFE	-20 to 450	-30 to 232	-150 <sup>(2)</sup> to 700	-100 to 371
	Braided PTFE Glass-filled PTFE	-20 to 500	-30 to 260		
150 - 600	SafeGuard <sup>(7)</sup> , SureGuard <sup>(7)</sup>	-20 to 450	-30 to 232	-20 to 600	-30 to 316
	SureGuard XT <sup>(7)</sup>	-20 to 550	-30 to 288	-20 to 700	-30 to 371
900 - 2500	SafeGuard <sup>(7)</sup> , SureGuard <sup>(7)</sup>	-20 to 450	-30 to 232	-20 to 700	-30 to 371
	SureGuard XT <sup>(7)</sup>	-20 to 550	-30 to 288	-20 to 800	-30 to 427

- (1) B16.34, 1988, specifies acceptable pressure/temperature limits for pressure retaining materials. Consult factory for additional information.
- (2) If the appropriate body and bonnet materials are used.
- (3) PTFE is rated to -423° F / -253° C.
- (4) 8 to 12-inch, Class 150 – 600; and 3 to 12-inch, Class 900 – 2500 can be used to 850° F / 454° C.
- (5) Asbestos-free, high temperature packing. (all major brands available)
- (6) Do not use Graphite above 800° F / 427° C in oxidizing service such as air.
- (7) Low leakage, low maintenance packing.

**Table III: Guides\***

Standard Materials	Maximum Temperature	Minimum Temperature	Maximum Pressure
Graphite lined SS**	1500° F / 816° C	-320° F / -196° C	1400 psig / 96.6 Barg thru 2-inch 1000 psig / 69.0 Barg 3 thru 4-inch 850 psig / 58.6 Barg 6-inch & up
Glass-filled PTFE-lined S.S.	350° F / 177° C	-423° F / -253° C	150 psig / 10.3 Barg @ 100° F / 38° C 100 psig / 6.9 Barg @ 350° F / 177° C
Solid Bronze	500° F / 260° C	-423° F / -253° C	Same as body
Solid Alloy 6	1500° F / 816° C	-423° F / -253° C	Same as body

- \* Refer to Sizing & Selection 12 for specific application guidelines.
- \*\* Do not use Graphite above 800° F / 427° C in oxidizing service such as air or oxygen. The use of Graphite packing may require oversize actuators or heavier springs due to added friction.

## Valtek Mark One-Power

### Trim Types, Flow Characteristics, Hard Facing

#### Trim Types

Valtek Mark One-P trims can easily be converted from one trim type to another. All seat rings and plugs within a given size and pressure class are interchangeable. Multiple trim reductions are available by changing only the plug and seat. Many other parts are interchange-

able between pressure classes (150 thru 600 and 900 thru 1500).

Standard full-area trim provides maximum  $C_v$ . Reduced trim is available in a wide variety of sizes when lower  $C_v$  and large bodies are required.

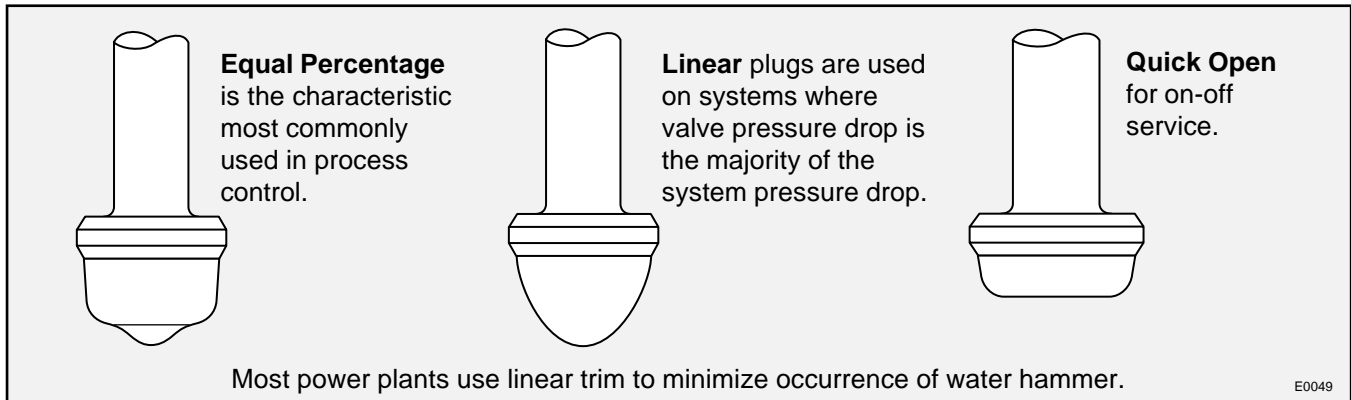

Figure 13: Flow Characteristics

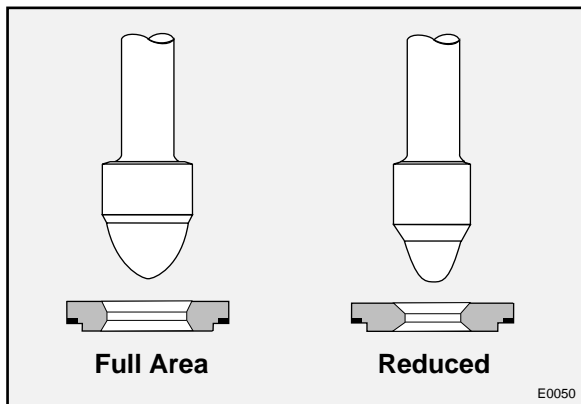

Figure 14: Typical Trim Types

#### Hardened Trim

For smaller valves the standard plug and seat ring material is 416 stainless steel, with solid Alloy 6 plug head and a 316 stainless steel stem as optional trim. On larger valves 316 stainless steel is used, with Alloy 6 or other overlays as an option. A general rule is to consider hardened trim for all steam and high differential pressure applications. These materials offer a good combination of relative hardness and corrosion resistance. Special alloy trims and hard facings are also available.

Table IV: Material Hardness Ratings

Trim Material	Hardness Rockwell C	Corrosion* Resistance
316 S.S.	8	Excellent
416 S.S.	40	Fair
Alloy 6	44	Good to Excellent
440C S.S.	56	Fair

\* General rule only. Check specific application.

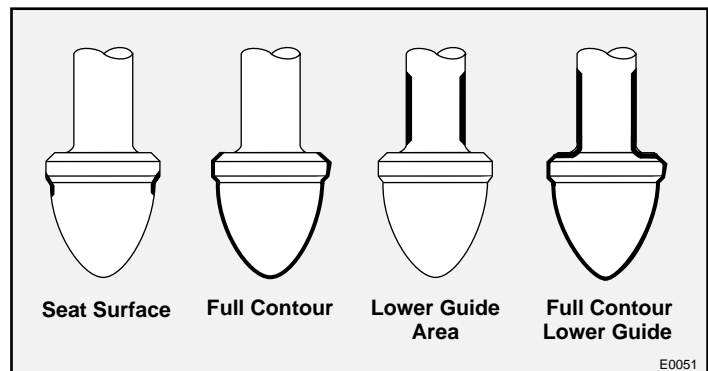

Figure 15: Hard Facing Variations – Seat

## Valtek Mark One-Power Pressure-balanced Trim, Seats, Seals

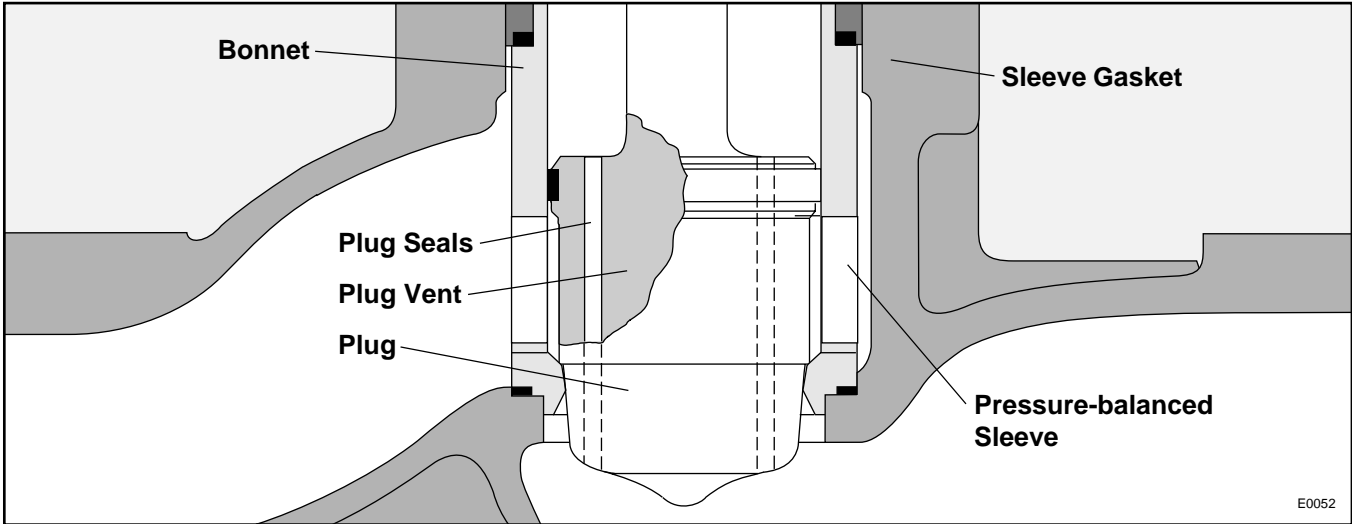

Figure 16: Pressure-Balanced Trim

### Pressure-balanced Trim

For extremely high-pressure drops, pressure-balanced trim is used to reduce the thrust necessary to stroke the plug by reducing the trim off-balance area.

The seal area less the stem area is designed to be slightly larger than the seat area. This results in an off-balanced plug which aids the valve to close for flow-under the seat and to open for flow over the seat. Flow direction is generally under the plug for fail-closed and over the plug for fail-open.

Table V: Pressure-balanced Seal Temperature Ranges

Seal Material	Temperature Range
Multi-seal piston rings*(1)	300° to 1600° F / 150° to 870° C
Ni-Resist piston rings(1)	300° to 600° F / 150° to 316° C
Kalrez® O-ring	-20° to 550° F / -30° to 288° C
Aflas® O-rings	-40° to 500° F / -40° to 260° C
Viton O-rings	-40° to 435° F / -40° to 222° C
PTFE seals	-320° F / -195° C @ full rating to 400° F / 204° C @ 1200 psi / 82.7 Bar

\* Multiple component ring; requires a hardened sleeve material.  
(1) Standard metal seals have two grooves (seals) in the plug.

### Metal Seats

Unbalanced metal-seated valves attain a standard of Class IV shutoff (ANSI/FCI 70-2, 1991), although Class V is optional. Class IV calls for maximum permissible seat leakage of 0.01 percent of rated valve capacity. All Valtek valves are seat-leak tested after assembly and generally are substantially lower in leakage than called for by this class. This exceptional seat tightness is obtained by aligning the seat ring with the plug during assembly.

### Soft Seats

The soft seat is used in applications requiring ANSI Class VI 'bubble-tight' shutoff. The design consists of an elastomer sandwiched between two metal pieces. The assembled soft seat is interchangeable with the hard seat for a given size and pressure rating. Inserts can be constructed of PTFE; therefore, the maximum temperature should be below 350° F / 177° C at 1000 psi / 68.9 Bar. For temperatures up to 400° F / 204° C, inserts of PEEK material can be used to 1500 psi / 103 Bar.

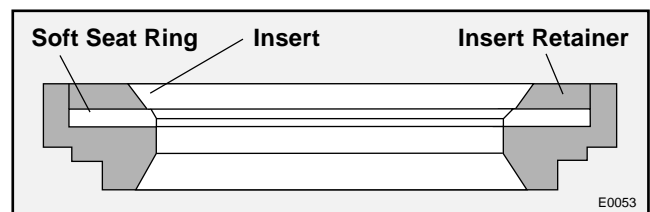

Figure 17: Typical Soft Seat Configuration

## Valtek Mark One-Power Materials of Construction

**Table VI: Body Materials**

Sizes	1/2 – 48 inch; Class 150 thru 600 1/2 – 24 inch; Class 900 thru 2500 1/2 – 12 inch; Class 4500
Forms	Globe, angle, 3-way, expanded outlet, Y-body
ANSI Ratings	Class 150, 300, 600, 900, 1500, 2500, 4500 and special classes
Materials	Carbon steel, chrome-moly (C5, WC6, WC9, WC12), 316 stainless steel, others as requested
End Connections	Buttweld, Socketweld, Threaded, Integral or Separable Flange

**Table VII: Bonnet Materials**

Types	Standard, standard extension, special length extension
Flange	Separable
Materials	Same as body

**Table VIII: Packing**

Configurations	Standard, Twin seal, Vacuum seal
Materials Safe-PTFE	AFP/INCONEL wire, Graphite, Guard, SureGuard (XT), V-ring, Braided PTFE, Glass-filled PTFE V-ring
Lubrication (optional)	Lubricator w/ or w/o integral isolation valve

**Table IX: Trim**

Characteristics	Equal percentage, Linear, Quick open
Materials	416, 420, 440C, 316 S.S., alloys
Hard Facings	Materials: Alloy 6 & 21, #5 Colmonoy®, Ultimet®
	Types: seat surface, full contour, full bore, lower stem guide area
Soft Seat	PTFE, FEP, KEL-F®, Polyurethane, PEEK
Pressure-balanced	Sizes: 2-inch and larger, Seal types: elastomer, metal

**Table X: Guides**

Type	Double-top stem
Materials	Bronze, Alloy 6, Graphite, PTFE, other materials as required

**Table XI: Gaskets**

Types	Spiral wound: 304, 316 S.S., INCONEL, non-asbestos; Graphite Flat: PTFE, glass-filled PTFE
-------	---

**Table XII: Actuators**

Types	Double-acting cylinder with positive fail-safe spring action, Manual handwheel, Electro-hydraulic, Electro-mechanical
Sizes	Cylinder: 25, 50, 100 square inch (standard); 200, 300, 400, 500, 600 square inch (optional) Manual handwheel: 9, 12, 18, 24-inch diameter
Auxiliary	Side-mounted: continuously connected Top-mounted: continuously connected, push-only, limit stops
Materials	Cylinder: anodized aluminum, steel Piston: anodized aluminum Actuator stem: 416 stainless steel Yoke: ductile iron O-rings: Buna N, EPDM, Viton®
Action	Air-to-open, Air-to-close (field reversible)

**Table XIII: Positioner**

Types	Pneumatic, Electro-pneumatic
Input Signals	Electro-pneumatic: 4-20, 10-50 mA Pneumatic: 3-15, 3-9, 9-15, 6-30 psi <b>0-1, 0-0.6, 0.6-1, 0.4-2.1 Bar</b>
Supply Pressure	40-150 psi / <b>2.8-10.3 Bar</b> (no supply regulator required)
Operating Temperature	-20° to 185° F / <b>-30° to 85° C</b> (std.) -50° to 250° F / <b>-45° to 121° C</b> (opt.)
Adjustments	Stroke range, zero
Action	Air-to-open, Air-to-close (field reversible)

## Valtek Mark One-Power Severe Service Trims

**Severe Service Trims** (Tiger-Tooth™, MegaStream™, ChannelStream™, and CavControl™) can be designed into most Valtek Mark One-Power control valves. This feature exemplifies the versatility of Valtek control products.

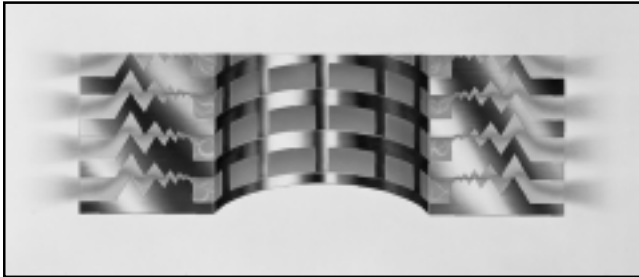

**Tiger-Tooth** trim eliminates cavitation in liquid services and reduces noise up to 30 dBA in gaseous services.

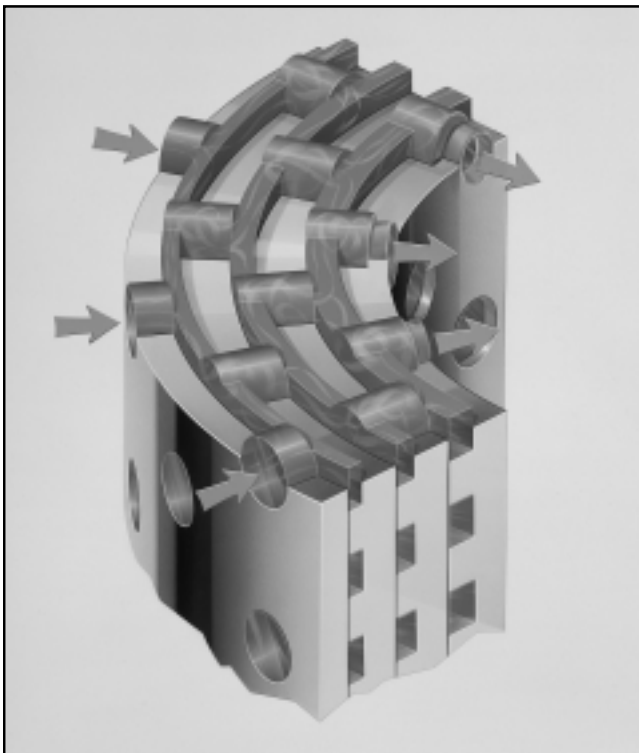

**ChannelStream** (above) trim in liquid services can prevent cavitation damage and associated damage, and hydrodynamic noise in the most demanding applications.

**CavControl** (right) trim can reduce cavitation damage in moderately cavitating services.

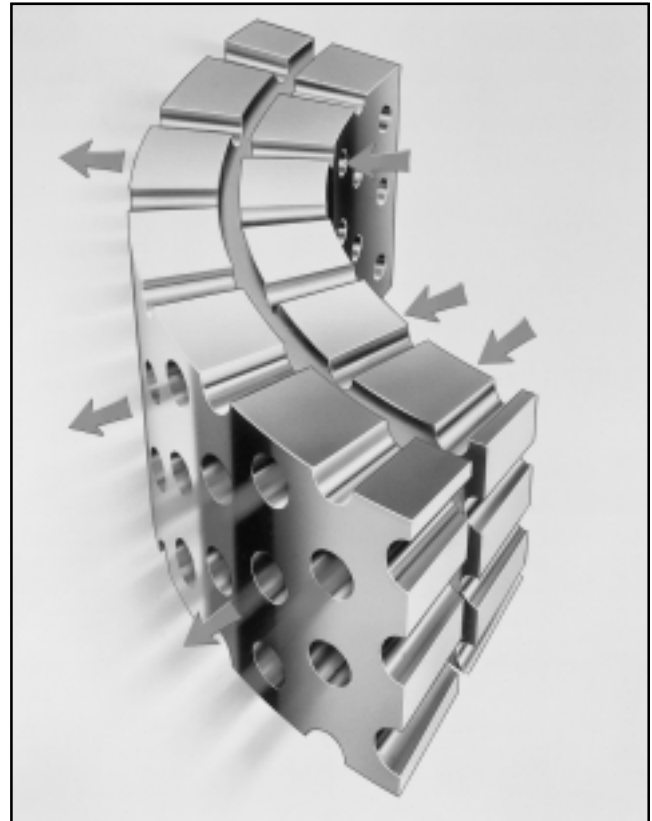

**MegaStream** trim is an economical choice for reducing noise by up to 28 dBA in gaseous services.

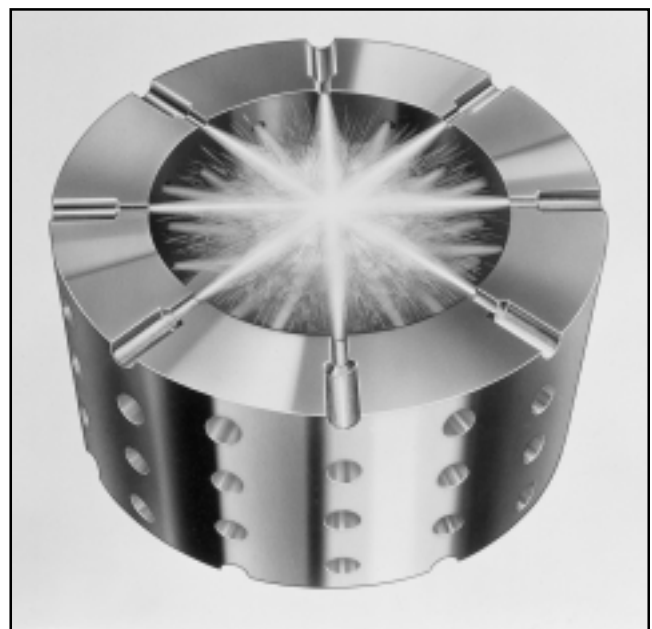

# Valtek Mark One-Power

## Dimensions

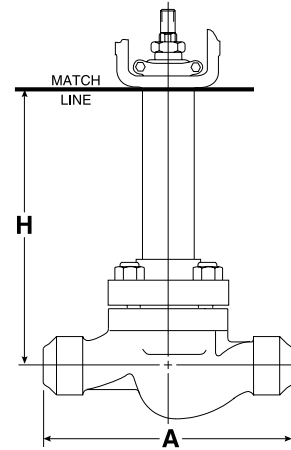
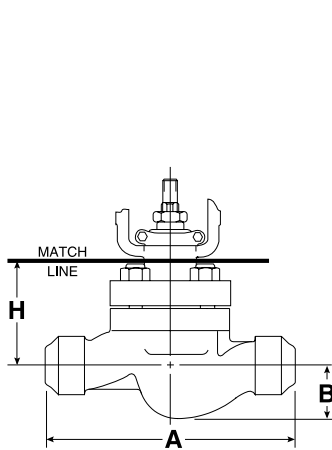

\*Valtek Standard, Differs from Standard Shown

E0054

**Table XIV: Globe Body Dimensions – Class 150, 300, 600 (inch / mm)**

Body Size (inches)	A				B		H				Clearance Above Actuator Required for Disassembly	
	Socket Weld & NPT		Buttweld				Standard Bonnet	Extended Bonnet				
	ANSI / ISA S75.12		ANSI / ISA S75.15									
	Class 150, 300, 600		Class 150, 300, 600									
.50 & .75	8.12*	206	8.12*	206	1.5	38	3.8	97	8.3	212	2.5	64
1	8.25	210	8.12*	206	1.8	44	3.8	97	8.3	212	2.5	64
1.5	9.88	251	9.88	251	2.3	59	5.2	132	9.7	245	4.0	102
2	11.25	288	11.25	286	2.3	57	5.4	138	9.9	252	4.5	114
3			13.25	337	3.4	86	6.8	172	12.3	312	5.8	147
4			15.50	394	5.2	133	8.4	214	13.9	354	7.5	190
6			20.0	508	5.8	146	12.3	311	17.8	451	10.0	254
8			24.0	610	7.5	190	14.4	365	19.9	505	11.4	290
10			29.62	752	8.9	227	14.1	359	20.6	524	12.1	308
12			32.25	819			16.3	413	22.8	578	12.6	320

**Table XV: Globe Body Dimensions – Class 900, 1500, 2500 (inch / mm)**

Body Size (inch)	A								B		H						Clearance Required for Disassembly							
	Socket Weld & NPT				Buttweld						Standard Bonnet			Extended Bonnet										
	ANSI / ISA S75.12		ANSI / ISA S75.15		ANSI / ISA S75.12		ANSI / ISA S75.15				Class 900,1500		Class 2500		Class 900,1500				Class 2500					
	Class 900, 1500	Class 2500	Class 900, 1500	Class 2500	Class 1500	Class 2500	Class 900,1500	Class 2500	Class 900,1500	Class 2500	Class 900,1500	Class 2500	Class 900,1500	Class 2500										
1	11.0	279	12.5	318	11.0	279	12.0*	305	1.8	44	1.8	44	5.6	143	6.8	173	10.1	257	11.3	286	3.6	90	3.6	90
1.5	13.0	330	15.0	381	13.0	330	15.0*	381	2.7	68	2.4	60	8.7	220	8.7	221	13.2	334	13.2	334	5.6	141	5.6	141
2	14.8	375	15.8	400	14.8	375	15.8	400	2.8	71	3.0	77	8.7	220	8.7	221	13.2	334	13.2	334	6.1	154	6.1	154
3					18.1	460	26.0*	660	4.2	106	3.7	94	11.4	289	12.9	328	18.4	467	19.9	506	8.4	214	8.3	211
4					20.9	530	29.0*	737	4.4	113	5.4	138	12.4	316	14.6	371	19.4	496	21.6	549	9.7	246	10.7	272
6					30.0*	762	34.0*	864	7.2	183	7.3	184	16.4	416	17.4	442	23.4	594	27.3	692	12.2	309	13.6	344
8					32.8	832	40.3	1029	9.4	240	10.3	262	18.6	473	24.3	616	24.2	613	31.3	794	16.7	424	17.8	451
10					39.0	991	50.0	1270	11.2	284	10.0	254	21.9	556	26.0	660	28.9	734	33.0	838	18.3	465	19.5	495
12					44.5	1130	56.0	1422	14.0	356	12.9	327	26.6	675	28.0	711	33.6	852	35.0	889	19.4	492	20.5	521
14					49.5	1257	71.0	1803					24.8	629			31.8	806			20.5	521		

\*Valtek Standard, Differs from Standard Shown



# Valtek Mark One-Power Dimensions

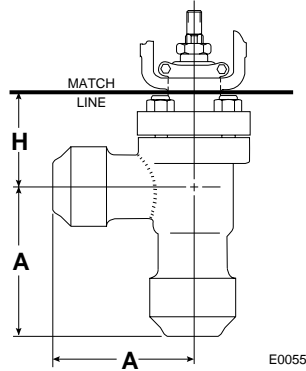

**Table XVI: Angle Body Dimensions – Class 150, 300, 600 (inch / mm)**

Body Size (inches)	Body Rating Class	A		H				Clearance Required for Disassembly	
				Standard Bonnet		Extended Bonnet			
.50 & .75	150 thru 600	4.25	206	3.1	78	7.6	192	2.5	64
1	150 thru 600	4.26	206	3.1	78	7.6	192	2.5	64
1.5	150 thru 600	4.75	251	3.6	92	8.1	206	4.0	102
2	150 thru 600	5.75	286	3.9	100	8.4	214	4.5	114
3	150 thru 600	7.00	178	4.9	124	10.4	264	5.8	147
4	150 thru 600	8.75	222	6.2	156	11.7	295	7.5	190
6	150	8.88	226	7.1	180	12.6	320	10.0	254
	300 thru 600	11.00	279	9.5	241	15.0	381	10.0	254
8	150	10.69	272	9.0	229	14.5	368	13.8	349
	300 thru 600	13.00	330	10.8	275	16.3	414	13.8	349

**Table XVII: Angle Body Dimensions – Class 900, 1500, 2500 (inch / mm)**

Body Size (inches)	Body Rating Class	A		H				Clearance Required for Disassembly	
				Standard Bonnet		Extended Bonnet			
1	900, 1500	5.50	140	3.1	78	7.6	192	2.5	64
	2500	6.00	152	5.8	147	10.3	262	3.6	90
1.5	900, 1500	6.50	165	6.5	165	11.0	279	5.6	142
	2500	7.50	191	7.0	178	11.5	295	5.6	142
2	900, 1500	7.25	184	7.1	180	11.6	295	6.1	155
	2500	8.88	226	7.9	201	12.4	315	6.1	155
3	900, 1500	9.25	235	9.8	249	16.8	427	8.4	213
	2500	13.00	330	11.2	284	18.2	462	8.3	211
4	900, 1500	12.50	318	11.1	282	18.1	460	9.7	246
	2500	14.50	368	12.6	320	19.6	498	10.7	272
6	900, 1500	13.88	353	13.3	338	20.3	516	12.2	310
	2500	17.00	432	16.1	409	23.1	537	13.6	345
8	900, 1500	16.38	417	14.5	368	21.5	547	16.7	424
	2500	20.12	511	20.8	528	27.8	706	17.8	452
10	900, 1500	19.50	495	15.6	396	22.6	574	18.3	465
	2500	25.00	635	21.1	536	28.1	714	16.3	414

## Valtek Mark One-Power Nuclear Services

Valtek control products are regularly supplied for nuclear power applications and holds "N" stamps for valves and parts built to the ASME Boiler and Pressure Vessel Code. Flowserve also participates in the NUPIC audit program. All valves described in this bulletin are available under the following standards:

- ASME Section III, Classes 1, 2, 3
- 10CFR50 Appendix B (safety related)
- ASME B16.34

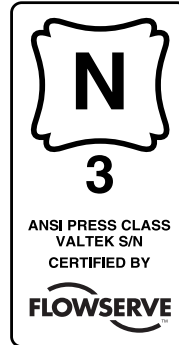

Flowserve Corporation has established industry leadership in the design and manufacture of its products. When properly selected, this Flowserve product is designed to perform its intended function safely during its useful life. However, the purchaser or user of Flowserve products should be aware that Flowserve products might be used in numerous applications under a wide variety of industrial service conditions. Although Flowserve can (and often does) provide general guidelines, it cannot provide specific data and warnings for all possible applications. The purchaser/user must therefore assume the ultimate responsibility for the proper sizing and selection, installation, operation and maintenance of Flowserve products. The purchaser/user should read and understand the Installation Operation Maintenance (IOM) instructions included with the product, and train its employees and contractors in the safe use of Flowserve products in connection with the specific application.

While the information and specifications presented in this literature are believed to be accurate, they are supplied for informative purposes only and should not be considered certified or as a guarantee of satisfactory results by reliance thereon. Nothing contained herein is to be construed as a warranty or guarantee, express or implied, regarding any matter with respect to this product. Because Flowserve is continually improving and upgrading its product design, the specifications, dimensions and information contained herein are subject to change without notice. Should any question arise concerning these provisions, the purchaser/user should contact Flowserve Corporation at any of its worldwide operations or offices. All tradenames and trademarks shown in this literature are the property of their respective owners.

For more information, contact:

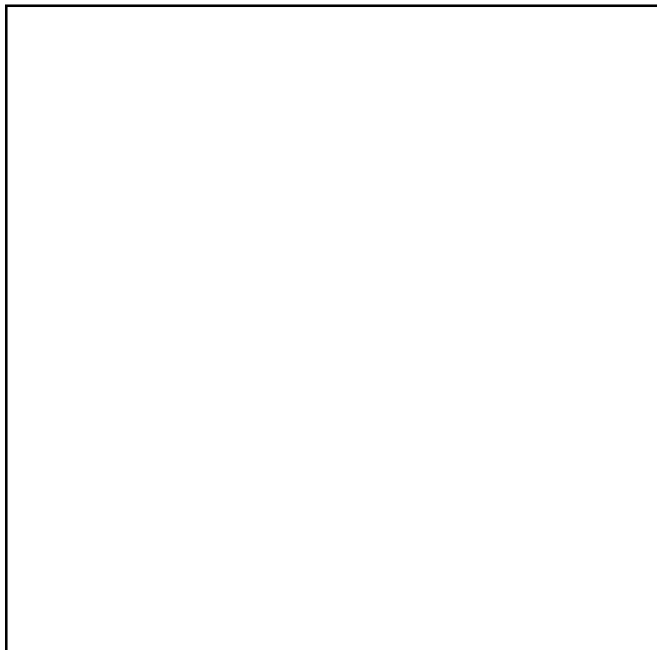

For more information about Flowserve and its products, contact [www.flowserve.com](http://www.flowserve.com) or call USA 972 443 6500

### Manufacturing Facilities

1350 N. Mt. Springs Prkwy.  
Springville, UT 84663  
Phone 801 489 8611  
Facsimile 801 489 3719

1300 Parkway View Drive  
Pittsburgh, PA 15205 USA  
Telephone 412 787 8803  
Facsimile 412 787 1944

Manderscheidstr. 19  
45141 Essen, Germany  
Telephone (49) 2 01 89 19 5  
Facsimile (49) 2 01 891 9600

Allée du Quartz 1  
CH-2300 La Chaux-de-Fonds  
Switzerland  
Telephone (41) 32 925 9700  
Facsimile (41) 32 926 5422

### Quick Response Centers

5114 Railroad Street  
Deer Park, TX 77536 USA  
Telephone 281 479 9500  
Facsimile 281 479 8511

104 Chelsea Parkway  
Boothwyn, PA 19061 USA  
Telephone 610 497 8600  
Facsimile 610 497 6680



APPROVED  
as

Fuel Service Valve  
CNFPA 86 A-B

